

Cargo Aids

- Our Semi-Automatic Cargo Release Unit (SACRU) is designed for aircraft lifting up to 6,000lbs (2,722 Kg) and is extensively used by the Royal Navy and Royal Air Force.
- The SACRU 1 Mk 2 has EMC protection and has been selected and approved by Agusta Westland for EH101 Navy Merlin MK1.
- The design is of simple construction involving no delicate mechanisms requiring fine adjustment.
- Certified by the CAA, variants of this cargo hook are also available as an FAA and Transport Canada approved bolt-on replacement hook for the Bell 204 through 412 series helicopters.
- The SACRU 1 is now available with load measurement to enable pilots to know the weight of the cargo and therefore monitor the airframe.

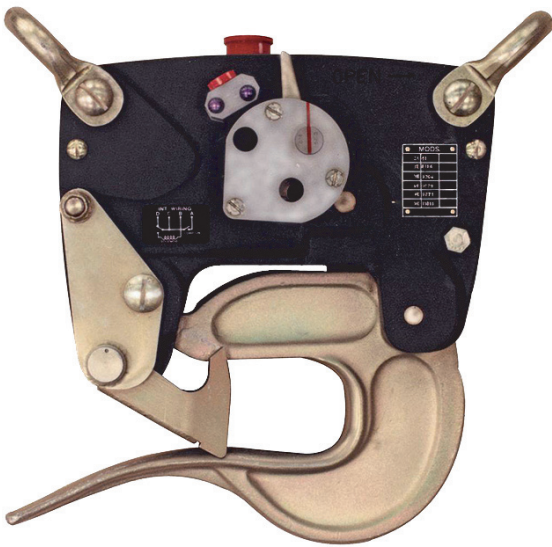

Agusta-Westland approved for EH101 Merlin

The SACRU 1 Mk 2 has been selected by Agusta-Westland for installation on EH101 Navy Merlin.

Releases 2.5 Times Rated Load

Capable of releasing 2.5 times rated load both mechanically and electrically, the SACRU 1 has an extra margin of safety, allowing the hook to be released in emergency overload situations.

Now Available with Load Measurement

The SACRU 1 is now available with Load Measurement which enables the pilot to avoid overload situations.

Hook Specification

Design Load:	6,000lb	(2,722 Kg)
Unit Weight:	13 lb	(5.9 Kg)
Proof Load:	18,000 lb	(8,180 Kg)
Ultimate Load:	27,000 lb	(12,247 Kg)
Electrical Release Capacity:	15,000 lb	(6,804 Kg)
Mech. Release Capacity:	17,940 lb	(8,137 Kg)
Man. Pull Off at Rated Load:	25 lb Max	(1.38" travel)
Minimum Release Load:	7 lb	(3.18Kg)
Electrical Requirement:	20-28vDC	(10 Amps)
Electrical Connector:	MS3102E-14S-2P	

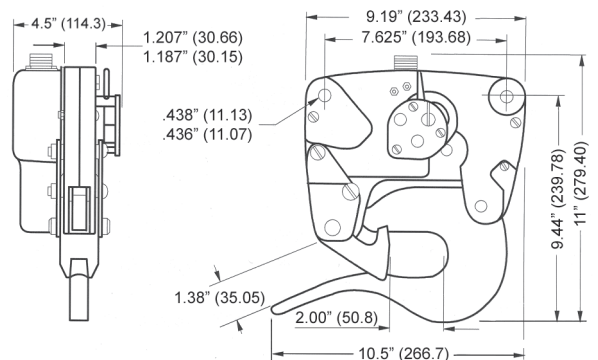

Part No. | Helicopter

SP7109-3B	Sikorsky S-61
SP7109-3B	Agusta Westland Wessex
SP7109-3B	Agusta Westland Sea King
SP7109-3B/2	Agusta Westland EH101 Navy Merlin
SP7109-3B	Eurocopter/Westland Puma

SACRU 1 Mk1 & Mk2 Cargo Hook

The Drallim Group

Leading innovators in technology and quality